

# TECHNICAL DATA SHEET

## LPI® SPD Module (Single Module and Base)

The LPI SST150B is a single mode power line shunt surge protection device rated for 50 kA 8/20  $\mu$ s single shot surge capacity ( $I_{max}$ ). The unit is designed for mounting at main power switchboards and distribution boards in category C locations as per the IEC and other international standards.

The LPI SST150B is designed to provide surge and transient protection in compliance with IEC 61643 international standards. The design allows it to be configured for Ph-N protection applications for single or multiple phases as required. It is also designed for easy mounting on standard 35 mm DIN rail.

The unit comes with fast, responsive Metal Oxide Varistors (MOV) to provide effective surge protection with low let-through voltage to protect sensitive electronics and electrical circuits.

The unit comes as a two-part item. The base is hardwired into the circuit to be protected, and the protection module is plugged into this base. This enables easy replacement of protection modules should they be degraded or damaged by excessive transient activity. The SST150B is supplied with Bluetooth connectivity as detailed in previous pages (refer to page 3).

### Technical Specifications

Protection Modes:	Ph-N
Status Indication:	LED display: showing operational condition
Bluetooth Connectivity:	Status indication, operating voltage, Harmonic THD %, Internal temp & Surge Impulse Count
Mounting:	TS 35 mm – DIN43880 DIN rail
Weight:	Approx. 127 grams
IP Rating:	IP 20
Colour:	Blue
Conductor Size:	35 mm <sup>2</sup> (Max)
Operating Temperatures:	-20 to +40 °C, 0 – 95 % humidity
Designed to Conform to:	IEC 61643-11 & UL 1449 Ed4 where applicable
Surge Withstand:	ANSI C62.41 Cat A, Cat B, Cat C, AS/NZS 1768-2007 Cat A, Cat B, Cat C
Application:	Main and sub-distribution boards
Configuration:	Hardwired base and pluggable module
Warranty:	5 years

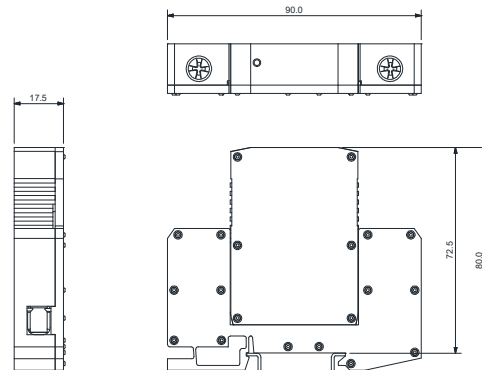

## TECHNICAL DATA SHEET

## LPI® Bluetooth Surge Protection Range

## Single Module and Base

Product Code:	Nominal Operating Voltage Un: @ 50/60 Hz	Surge Rating (Imax): @ 8/20 µs	Nominal Discharge Current (In): @ 8/20 µs	Max. Continuous Operating Voltage (Uc):	Voltage Level at 20 kA 8/20 µs:	Response Time:	Power Distribution Systems:
<b>SST150B-230</b>	110-120Vac	50 kA	20 kA	230 Vrms	< 0.8Kv	<5 ns	TT & TN for L-N mode
<b>SST150B-385</b>	220-240 Vac	50 kA	20 kA	385 Vrms	<1.3 kV	<5 ns	TT & TN for L-N mode
<b>SST150B-480</b>	220-277 Vac	50 kA	20 kA	480 Vrms	<1.7 kV	< 5 ns	TT & TN for L-N mode

## Replaceable Surge Module

Product Code:	Nominal Operating Voltage Un: @ 50/60 Hz	Surge Rating (Imax): @ 8/20 µs	Nominal Discharge Current (In): @8/20 µs	Max. Continuous Operating Voltage (Uc):
<b>SST150B-230-Module</b>	110-120Vac	50 kA	20 kA	230 Vrms
<b>SST150B-385-Module</b>	220-240 Vac	50 kA	20 kA	385 Vrms
<b>SST150B-480-Module</b>	220-277 Vac	50 kA	20 kA	480 Vrms

## TECHNICAL DATA SHEET

**Installation Guide for SST150B**

**All installation work must be carried out by licensed electrical personnel.**

**Location:**

The shunt protection device should be installed at the “point of entry” of the power mains, but after the power meter and main breaker in order to protect downstream power connected equipment.

**Installation:**

Refer to table for recommended fuse and cable sizes.

1. Ensure power is disconnected prior to commencing installation.
2. The unit is labelled showing the incoming (point of entry) and outgoing (load) terminals to be used for enclosure and backplane units only.

PHASE IN and PHASE OUT are at the top of the unit whilst the EARTH and NEUTRAL are at the bottom.

3. Ensure that the “V” or Kelvin connections as per figure 3a. are observed.
4. Incoming cabling should enter the enclosure or backplane from the bottom.
5. The earth terminal must be connected to a low impedance earth ( $<10 \Omega$ ) deploying a single point earthing system, which should be connected to an equipotential earth plane. Integral to this is the elimination of earth loops. It is common, but incorrect from the point of lightning protection to have separate earths for various services. The use of single or multi core copper earth cable of not less than  $25 \text{ mm}^2$  (max.  $35 \text{ mm}^2$ ) is recommended.
6. Once connections are completed apply power and observe correct operation, place the provided LPI APP sticker to the outside of the enclosure or cabinet as to indicate Bluetooth connection is available to the surge diverter.



**LPI App Sticker**

## TECHNICAL DATA SHEET

**Connection options:**

1. It is recommended that the “V” or Kelvin connection be employed as shown at Figure 3a to minimise the over voltage applied on the protected equipment. Be sure not to run input and output wiring parallel.

2. If “V” connection is not possible, “T” connection is preferred as shown at Figure 3b. With this connection method, the input lead length should be kept as short and thick as possible and the wires should be bundled together.

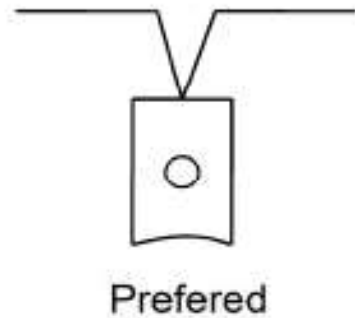

Figure 3a. Connection to Modules

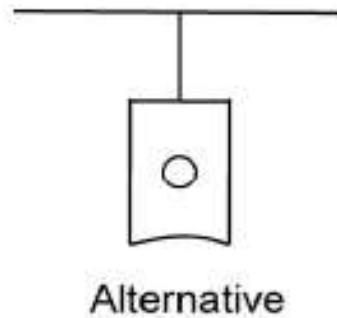

Figure 3b. Alternative Connection

## TECHNICAL DATA SHEET

## LPI® Spark Gap Shunt Protector - SG Range



## Features

- Encapsulated Spark Gap Technology
- Low follow on current
- 35mm DIN rail mount

The LPI Spark Gap Protector is a high performance encapsulated spark gap offering a high surge rating with low follow on current, ideal for point of entry protection. It is intended for installation within the lightning protection zone concept at the boundaries LPZ O<sub>A(B)</sub>-1 according to IEC 62305-4.

The LPI Spark Gap Protector has been designed for the protection of Phase-to-Neutral, Phase-to-Earth, or Phase-to-Neutral-Earth protection in LV supply systems.

Follow on current performance for these devices is kept within acceptable levels by the rapid extinguishment of the arc allowing transients to be clamped without activating upstream protection devices.

Ordering Code		SGT50-25
Nominal Operating Voltage:	$U_N$	230 Vac @ 50/60 Hz
Max. Continuous Operating Voltage:	$U_c$	255 Vrms (up to 480 Vrms, however with lower follow current extinguishing capability)
Follow current extinguishing capability at: $U_c$ :	$I_f$	25 k Arms
Voltage protection level at: $I_{imp}$ :	$U_p$	<2.0 kV
Max. lightning impulse current:	$I_{imp}$	50 kA (10/350 $\mu$ s)
Max. discharge current:	$I_{max}$	135 kA (8/20 $\mu$ s)
Max. lightning charge:	Q	25 As
Specific energy:	W/R	625 kJ/ $\Omega$
Insulation resistance:	$R_i$	>100 M $\Omega$
Response time:	$t_a$	<100 ns
Standard:		IEC 61643 and EN 61643
Recommended backup fuse:		315 AgL/gG
Operating temperature section of connected conductors range:		-40 to +70 °C
Recommended cross-section		50 mm <sup>2</sup> (solid) or 35 mm <sup>2</sup> (flexible) (at 4Nm clamping force)
Protection type:		IP 20
Mounting:		DIN rail 35 mm
Housing material:		SLOVAMID 6FRC2
Weight:		224 g
Application:		Main and sub-distribution boards (>100 A capacity)
Dimensions:		65 mm (H) x 35 mm (W) x 90 mm (L)
Warranty:		5 Years

# TECHNICAL DATA SHEET

## Installation Guide for Spark Gap

The use of a closed, high performance spark gap (gas filled) renders the blow-out vent superfluous. A safety gap between adjacent components for fire protection reasons is unnecessary. The installation of this unit is normally in the main distributor at the building entrance. The protection circuit is contained in a snap-on housing for installation on 35 mm DIN rail (in compliance with EN 50022) with multi-function terminals for wires and wiring bridges.

As this protector has to discharge lightning currents of up to 50 kA or 60 kA (10/350  $\mu$ s), we recommend the use of stranded copper cable of 35 mm<sup>2</sup>. Connections should preferably be tightened to 3 Nm. The entire length of the cable should not exceed 0.5 m. However, if it does exceed 0.5 m, the PE line should be installed with a Kelvin connection. This device must not be bonded exclusively via the wiring bridge. Lightning currents must be discharged via a cable with an adequate cross-sectional area. Protected and unprotected lines must not be laid together.

The LPI® SGT range may only be mounted and installed by suitably qualified personnel in compliance with the applicable standards. This device may only be used in the 3 + 1 circuit as an N/PE lightning current protector. We recommend that after the period when thunderstorms are most frequent, the connections for this lightning current protector be re-tightened.

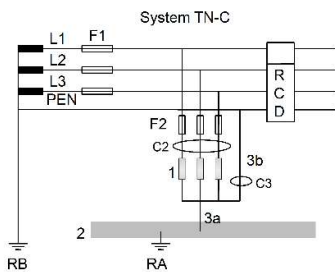
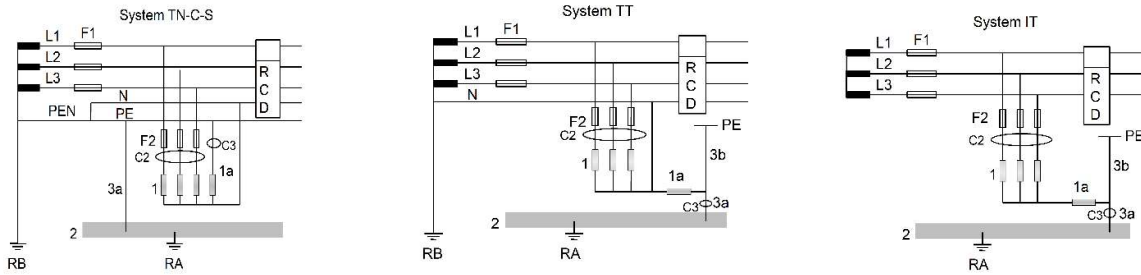

**Legend**

- 1 - LPI SGT50-25/ SG60
- 1a - LPI NE100
- 2 - Main equipotential bus bar
- 3a, 3b - Grounding wires for arresters
- F1 - Main back-up fuse of service main
- F2 - Recommended back-up fuse 315AgL/gG (only if the main back-up fuse F1 is fitted with back-up fuses >315AgL/gG)
- RA - Equipment grounding
- RB - Grounding system

**Schematic Diagram for different distribution system**

Fuse F1 gL/gG	C2 mm <sup>2</sup> connection at F2	C3 mm <sup>2</sup> connection to ground	Fuse F2 gL/gG
100 A-125 A	16	16	-
160 A	25	25	-
200 A-315 A	35	35	-
≥ 500 A	35	35	315 A

# TECHNICAL DATA SHEET

## LPI® Neutral / Earth Module



### Features

- Encapsulated spark gap technology
- Low follow on current
- 35 mm DIN rail mount
- NE-15B Bluetooth Connectivity

The LPI NE range lightning arrester is intended for applications in unmeasured parts of electrical installations within the lightning protection zones concept at the boundaries LPZ 0 A(B) -1 (according to IEC 62305-4).

The LPI NE range of lightning arresters are constructed as encapsulated (non-venting) chamber carbon spark gaps.

The LPI NE range is a single pole neutral–earth high energy protection device to protect electronic equipment from lightning current surges.

### Technical Specifications

Product Code:	NE-15B	NE-100
Nominal Operating Voltage: $U_n$	230 V/50 Hz	
Max. Continuous Operating Voltage: $U_c$	255 V/50 Hz	
Voltage Protection Level at Limp: $U_p$	<1.5 kV	<2.0 kV
Max. Lightning Impulse Current: $I_{imp}$	15 kA (10/350 $\mu$ s)	100 kA (10/350 $\mu$ s)
Max. Lightning Impulse Current: $I_{max}$	80 kA (8/20 $\mu$ s)	150 kA (8/20 $\mu$ s)
Specific Energy: W/R	50 kJ/ $\Omega$	2500 kJ/ $\Omega$
Insulation Resistance: $R_i$	>1000 M $\Omega$	
Response Time: $t_A$	<100 ns	
Standard:	IEC 61643 and EN 61643	
Operating Temperature Range:	-40 to +80 °C	-40 to +70 °C
Recommended Cross-Section of Connected Conductors:	10 mm <sup>2</sup> (at 3 Nm clamping force)	50 mm <sup>2</sup> (solid) or 35 mm <sup>2</sup> (flexible) (at 4 Nm clamping force)
Status Indication:	LED display: showing operational condition	-
Bluetooth Connectivity:	Status indication, operating voltage, Harmonic THD %, Internal temp & Surge Impulse Count	-
Protection Type:	IP 20	
Mounting:	DIN rail 35 mm	
Housing Material:	SLOVAMID 6FRC2	
Colour:	Dark blue	
Weight:	107 g	374 g
Application:	Main and sub-distribution boards (between N&E conductors only)	Main and sub-distribution boards (between N&E conductors only)
Dimensions:	80 (H) x 17.5 (W) x 90 mm (L)	65 (H) x 35 (W) x 90 mm (L)
Warranty:	5 Years	

### IMPORTANT INFORMATION:

NE-15B: The Neutral and phase terminals are polarity sensitive, installation to be completed as per illustrations on pages 15 & 16.

# TECHNICAL DATA SHEET

## LPI® Alarm Interface Modules



AIMCB

- Instant connection to surge units, no interaction required
- Ability to connect to 19 x SST150B units
- Combination of Bluetooth communication and volt free contact output



AIMCB for DIN mount use

### Technical Specification

Product Code:	AIMCB
Status Indication:	LED showing operational condition
Bluetooth Connectivity:	Status indication
Mounting:	TS 35 mm – DIN43880 DIN rail
Weight:	Approx. 135 grams
IP Rating:	IP20
Colour:	Blue
Conductor Size:	2.5 mm <sup>2</sup>
Operating Temperatures:	-20 to +60 °C, 0 – 95 % humidity.
Contact Rating:	Max switching voltage: 250 Vac / 220 Vdc Max switching current: 2 A Max carrying current: 2 A Max switching power: 60 W / 125 VA

### Accessibility

The alarm and surge modules are accessible through the LPI SPD App. Simply scan the QR code below or from the LPI sticker located on applicable enclosures to be taken to the LPI website and choose from iOS, Android or Windows applications.

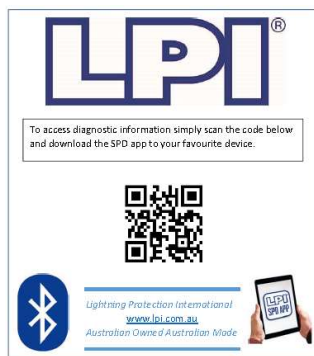

Sample sticker



LPI SPD APP QR code

TECHNICAL DATA SHEET

**DIN Mount and PPM Range**

**Module Combination DIN Mount (DR)**

Single or 3 phase combinations

- Pre-wired, DIN-Rail mounted, ready for quick install
- Customisable to kA rating capacity
- Dedicated neutral-earth protector



**Compact Enclosure (PPM)**

- IP67
- Surface mount
- Aluminium enclosure
- Single or 3 phase applications
- With or without integrated connection leads
- Small compact installation
- Connection leads Flexible multi-core (4 core + earth), 16 mm<sup>2</sup>, Earth 4 mm<sup>2</sup>, XHF-110 supplied as 1.5 m length. Installer should cut to length to suit installation
- Screw down lid



Notes:

1. Refer to Page 5 for SST150B specification detail.
2. Refer to Page 11 for neutral to earth protector specification detail.
3. Refer to page 12 for alarm module specification detail.

**Enclosure**

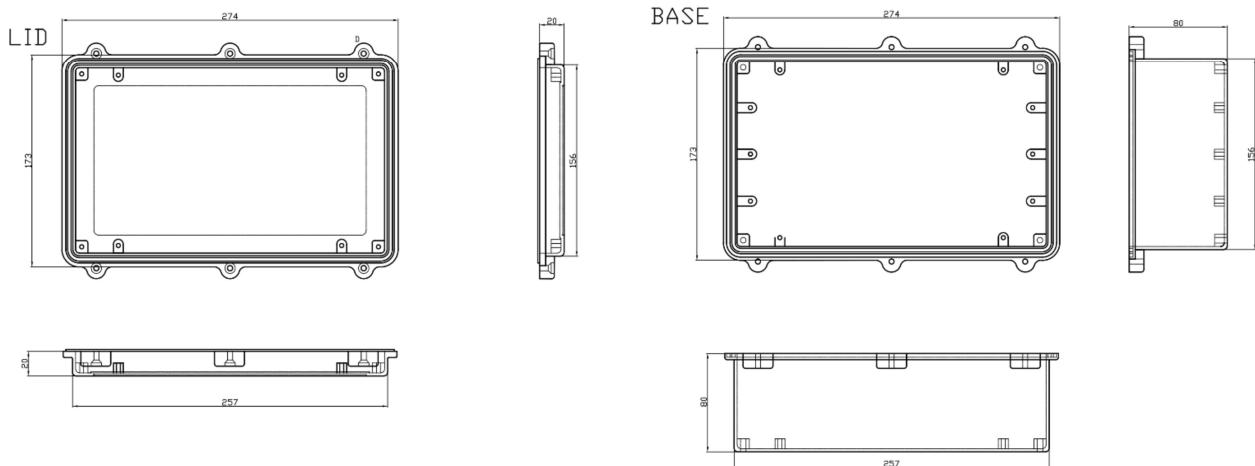

IP67 base complete with gasket, aluminium light grey painted, surface mount via external feet

# TECHNICAL DATA SHEET

## DIN Mount & PPM Part Number Key

Key	Connection Type	Code	Key	Mounting	Code	Key	Surge Rating	Code
A	Single Phase	1	A	Metal Enclosure	PPM	A	50 kA	50KA
B	3 Phase	3	B	Din Mounted (No Enclosure)	DR	B	100 kA	100KA
C	Split Phase	2	C	Backplane	BP	C	150 kA	150KA
						D	200 kA	200KA

Key	MCOV	Code	Key	Neutral / Earth	Code	Key	Alarm Module	Code
A	230 V	230V	A	NE15	NE15	A	Contact / Bluetooth	AIMCB
B	385 V	385V	B	NE100	NE100	B	Alarm Module Not Required	
C	480 V	480V	C	Neutral / Earth Not Required				

### Sample

AAB-B-A-A = 1PPM100KA-385V-NE15-AIMCB

### Connection Lead for PPM

- If connection lead is required to be supplied with PPM add "T" to product code following "PPM"  
Example: 1PPMT100KA-385V-NE15-AIMCB
- Connection lead is supplied as a 1.5 m length
- Installation contractor should cut length of lead to suit installation

# TECHNICAL DATA SHEET

## Installation Guide for DR Product Range Including Neutral/Earth Range

### IMPORTANT INFORMATION:

NE-15B: The Neutral and phase terminals are polarity sensitive, installation to be completed as per illustrations below.

### Connection Diagram for 1DR50KA-385-NE15

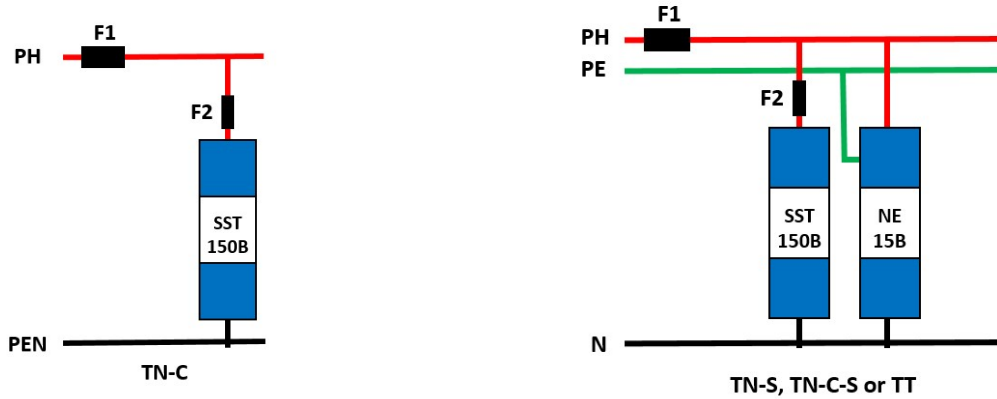

Note: For 100 kA and above, connect the Ph1 to one of the SST150B modules only.

### Connection for 3DR50KA-385-NE15

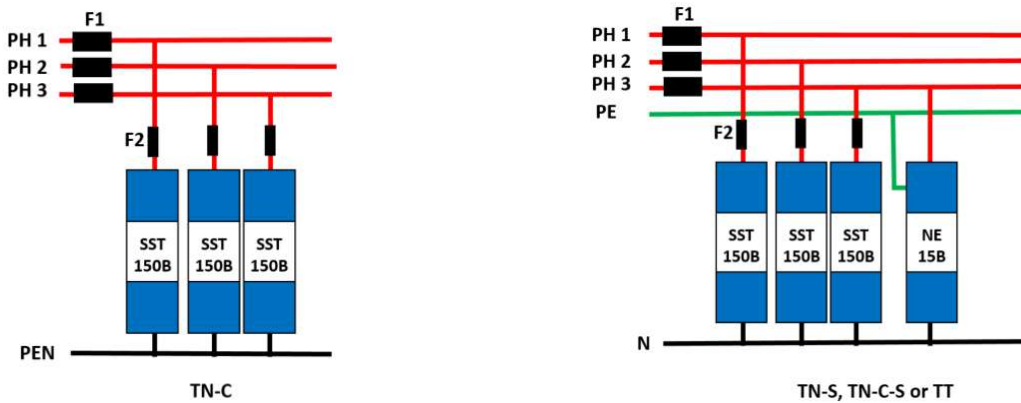

Note: For 100 kA and above, connect the Ph1, Ph2 and Ph3 to the first, third and fifth SST150B modules only

### Recommended Fuse and Cable Sizes

Fuse F1 gL/gG	C2 mm <sup>2</sup> connection at F2	C3 mm <sup>2</sup> connection to gnd	Fuse F2 gL/gG
25 A-80 A	10	16	-
100 A	16	16	-
125 A	16	16	-
160 A	25	25	-
≥160 A	25	25	160 A

Fuse and cable size for NE-15B

Fuse F1 gL/gG	C2 mm <sup>2</sup> connection at F2	C3 mm <sup>2</sup> connection to gnd	Fuse F2 gL/gG
25 A-80 A	10	16	-
100 A-125 A	16	16	-
160 A	25	25	-
200 A-315 A	35	35	-
≥500 A	35	35	315 A

Fuse and cable size for NE-100

TECHNICAL DATA SHEET

Installation Guide for DR Product Range including Neutral/Earth Range

<p>PH</p> <p>PE</p> <p>F2</p> <p>SST 150B</p> <p>NE 15B</p> <p>N</p>	
<p>PH</p> <p>PE</p> <p>F1</p> <p>F2</p> <p>SST 150B</p> <p>NE 15B</p> <p>N</p>	
<p>PH</p> <p>PE</p> <p>F2</p> <p>SST 150B</p> <p>NE 15B</p> <p>N</p>	

# TECHNICAL DATA SHEET

## Installation Guide for PPM Product Range

**All installation work must be carried out by licensed electrical personnel**

### Location

The Shunt Protection device should be installed at the “Point of Entry” of the power mains, but after the power meter and main breaker so as to protect the downstream power connected equipment.

### Ensure power is disconnected prior to commencing installation.

1. The unit is labelled showing the incoming (point of entry) terminals to be used. PHASE IN are at the top of the unit whilst the EARTH and NEUTRAL are at the bottom.
2. Ensure that the “V” or Kelvin connections, refer Page 8.
3. Incoming cabling should enter the enclosure on the left-hand side and load side cables should exit the enclosure on the right-hand side. This separation is important to ensure induction from “dirty” to “clean” lines does not occur.
4. The earth terminal must be connected to a low impedance earth (<10 Ohms) deploying a single point earthing system, which should be connected to an equipotential earth plane. Integral to this is the elimination of earth loops. It is common, but incorrect from the point of lightning protection to have separate earths for various services. The use of single or multi core copper earth cable of not less than 25 mm<sup>2</sup> (Max. 50 mm<sup>2</sup>) is recommended.
5. Once connections are completed apply power and observe correct operation.

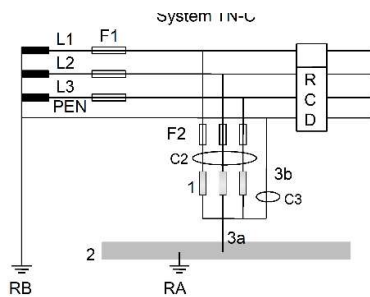
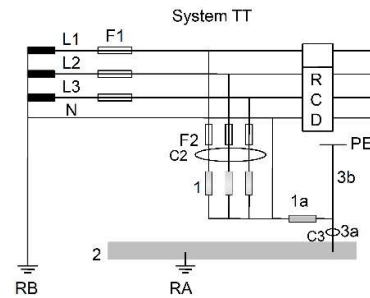
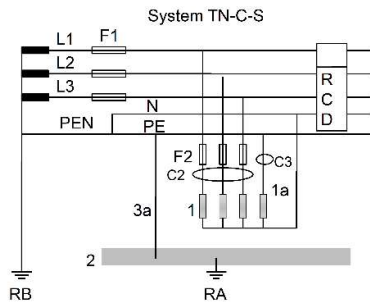

### Legend

- 1 - LPI SST150B
- 1a - LPI NE100
- 2 - Main equipotential bus bar
- 3a, 3b - Grounding wires for arresters
- F1 - Main back-up fuse of service main
- F2 - Recommended back-up fuse 315 AgL/gG (only if the main back-up fuse F1 is fitted with back-up fuses >315 AgL/gG)
- RA - Equipment grounding
- RB - Grounding system

### Recommended Fuse and Cable Sizes

Fuse F1 gL/gG	C2 mm <sup>2</sup> connection at F2	C3 mm <sup>2</sup> connection to gnd	Fuse F2 gL/gG
25 A-80 A	10	16	-
100 A-125 A	16	16	-
160 A	25	25	-
200 A-315 A	35	35	-
≥500 A	35	35	315 A

All PPMs are supplied with cable ties securing SST150B modules for transport purposes only. Remove all cable ties when installing.