

TECHNICAL DATA SHEET

LPI® Bluetooth Range of Surge Filters

Features



- High performance surge protector for an operating voltage of 220-277 Vac
- SST150B technology for primary and secondary protection 32 A- 125 A (1 Ph & 3 Ph)
- Encapsulated spark gap and SST150B technology capable of operation under fault/overvoltage conditions up to 480 Vrms for 200 A filter and above
- Three stage protection provides highest level of protection for sensitive electronic equipment

Product Description

- Designed to suit TT, TN-C, TN-S & TN-C-S distribution systems
- Inductors – dv/dt and di/dt of the incoming surge will be reduced by 1000 times
- 32 – 125 A filters primary (150 kA 8/20 μ s) and secondary (50 kA 8/20 μ s)
- 200 – 630 A filters primary (50 kA 10/350 μ s, 135 kA 8/20 μ s) and secondary (50 kA 8/20 μ s) surge protection. (NOTE: For 800 A and above, primary protection is 100 kA 10/350 μ s.)
- High N-E protection rating– 100 kA 10/350 μ s, 150 kA 8/20 μ s
- LED Indication, remote alarm contacts, MOV status indication.

Electronic equipment is highly susceptible to damage from lightning and other transient pulses (including man made switching transients), which arrive via the powerlines through direct strike, or inductive and capacitive coupling.

The LPI Bluetooth series surge filter provides multiple stage protection against incoming surges & transients. Shunt-only clamping alone is not sufficient, as it does not limit the excessive wavefront characteristic of the pre-clamped waveform. The LPI surge filter will reduce the rate of rise of voltage (dv/dt) to below 15 V/ μ s as per AS1768 Cat B 3 kA (8/20 μ s) applied impulse and to below 30 V/ μ s for AS 1768 Cat C 20 kA (8/20 μ s) applied impulse.

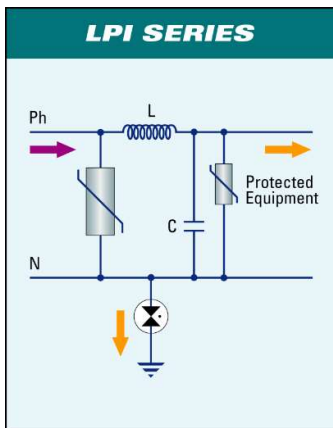

- Low let-through voltage
- Wavefront slowed (low)
- Energy diverted and filtered
- Poor power conditions
- Based on load current
- Vital for sensitive electronics
- Fine protection
- Common & differential mode

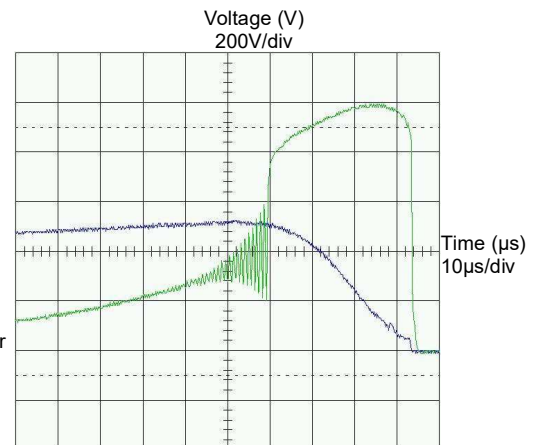

Green: Shunt Protector
Blue: Series Filter

TECHNICAL DATA SHEET

LPI® Bluetooth Range of Surge Filters 32-125 A (Single and Three Phase)

Technical Specifications

Description	LPI® Bluetooth Range of Surge Filters 32-125 A (Single and Three Phase)		
Nominal Operating Voltage U_n :	220 – 240	V AC P-N @ 50/60 Hz	220 - 277
Max Continuous Operating Voltages U_c :	385 Vrms	385 Vrms	480 Vrms
Operating Time:	< 1 ns		
Power Distribution Systems:	TT, TN-S, TN-C, TN-C-S (MEN)		
Primary Surge Protection Rating P-N:	Configurable 100 kA 8/20 μ s single-shot rating replaceable modules* ¹		
Secondary Surge Protection Rating P-N:	Configurable 50 kA 8/20 μ s single-shot rating replaceable modules* ²		
N-E Protection:	100 kA 10/350 μ s I_{imp} Class 1 to IEC 61643-11 255 V rms or 150 kA 8/20 μ s I_{max}		
Protection Modes:	Transverse and common mode		
Inductor:	Non-saturating, low pass, power and noise filtering		
Capacitor Type:	Separately-fused, self-healing, X-grade rating at high voltage ratings		
Surge Counter :	Build-in memory retained surge counter displayed via LPI SPD App		
Efficiency:	99 %		
Overload / Short Circuit Protection:	In-line circuit breaker, for 32 A, 40 A and 63 A only		
Performance:	Typical let-through voltage < 700 V		
Filter 3 dB Point:	Approximately 4000 Hz		
Standards (Primary and Secondary) :	Meets requirements of IEC 61643-11 and UL1449 Ed 3		
Standards (N-E):	Meets requirements of IEC 61643-11		
Surge Withstand:	ANSI/IEEE C62.41, AS/NZS 1768 Cat. A, B and C surge tests		
Protection Status Indication:	Bluetooth connectivity on status of MOV, surge counts, voltage and temperature. LED Status and voltage-free change-over contact output		
Environmental Rating:	IP 66		
Enclosure:	Metal enclosure with durable powder coat finish		
Colour:	Grey		
Mounting:	Wall mount		
Operating Temperatures:	-20 to +40 °C, 0 – 95 % humidity		
Conductor Size:	Accepts up to 35 mm ² (M8 Studs)		
Warranty:	5 years manufacturer's warranty		

*1 Configurable 50, 100, 150 or 200 kA 8/20 μ s

*2 Configurable 50 or 100 kA 8/20 μ s

TECHNICAL DATA SHEET

**LPI® Bluetooth Range of Surge Filters 200 A and Above
(Three Phase)**

Technical Specifications

Description	LPI® Bluetooth Range of Surge Filters 200 A and Above
Nominal Operating Voltage Un:	220 – 240 V AC P-N @ 50/60 Hz 220 - 277
Max Continuous Operating Voltage Uc:	385 Vrms 480 Vrms
Operating Time:	< 1 ns
Power Distribution Systems:	TT, TN-S, TN-C, TN-C-S (MEN)
Primary Surge Protection Rating per Phase:	135 kA 8/20 µs single shot surge capacity between phase and neutral. 800 A and above, phase to neutral protection is 110 kA 10/350 µs.
Secondary Surge Protection Rating per Phase:	50 kA 8/20 µs single shot surge capacity between phase and neutral, Bluetooth Technology
Total Surge Protection per Phase:	185 kA 8/20 µs
N–E Protection:	100 kA 10/350 µs, 150kA 8/20µs. For 800 A and above, neutral to earth protection is 100 kA 10/350 µs.
Protection Modes:	Transverse and common mode
Inductor:	Air-Cored, low pass, power and noise filtering
Capacitor Type:	Self-healing X grade
Surge Counter:	Build-in memory retained surge counter displayed via LPI SPD App
Current Crest Factor:	> 3:1
Voltage Drop:	< 2 V at full load
Efficiency:	99 %
Frequency Response:	3 dB point below 3000 Hz
Performance:	Typical let-through voltage for all models < 2 x mains peak voltage
Standards (Primary and Secondary):	IEC 61643-1
Standards (N-E):	IEC 61643-1
Surge Withstand:	ANSI/IEEE C62.41 and AS 1768 Cat. A, B and C surge tests
Environmental Rating:	IP 66
Enclosure:	Metal enclosure with durable polyester powder coat finish
Colour:	RAL 7032
Mounting:	Wall mount
Operating Temperatures:	-35 to +40 °C, 0 – 95 % humidity
Warranty:	5 years manufacturer's warranty

TECHNICAL DATA SHEET

Specification Detail for SPD Modules Used in Surge Filters

LPI® Bluetooth Connectivity for Surge Filters

Refer to Page 3 for further details.

Version 8 and above	Windows 10 / Windows 10 mobile	Version 4.3 and above



LPI® SST150B Module

Primary and Secondary protection for surge filters. Refer to page 5 & 6 for specification detail.

- Applicable to 32 A – 125 A surge filter, primary and secondary protection
- Applicable to secondary protection for 200 A surge filters and above

LPI® Spark Gap

Primary protection for 200 A surge filters. Refer to page 9 for specification detail.



LPI® Neutral / Earth Protection for Surge Filters

Refer to page 11 for specification detail.

LPI® Alarm Interface Module (AIMCB)

Refer to page 12 for specification detail.

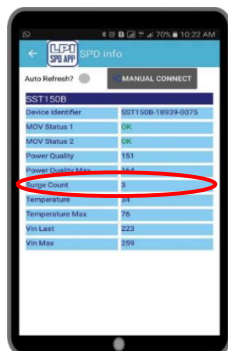

Surge Counter

The LPI Bluetooth range of SPD modules removes the need for a hardwired surge counter to be included with surge filters. As highlighted in the attached image a surge count is given via Bluetooth connectivity for each module. For three phase applications, this information assists in identifying problem issues where one phase maybe carrying more current than other phases.

TECHNICAL DATA SHEET

Summary of Specification Detail for Surge Filters

Surge Filter Type	Enclosure Dimensions mm (Unpacked: W x H x D)	Weight kg (Unpacked)
SF132	300 x 300 x 150	5
SF140	300 x 300 x 150	6
SF163	300 x 300 x 150	6
SF1125	300 x 300 x 150	7
SF332	400 x 400 x 150	10
SF340	400 x 400 x 150	10
SF363	400 x 400 x 150	10
SF3125	400 x 400 x 150	11
SF3200	500 x 600 x 200	40
SF3315	600 x 700 x 200	64
SF3400	600 x 700 x 200	64
SF3630	1200 x 800 x 350	105
SF3800	1200 x 800 x 350	153
SF31000	1200 x 800 x 350	165
SF31250	1200 x 800 x 350	165
SF31500	1200 x 800 x 350	170
SF31750	1200 x 800 x 350	175
SF32000	1200 x 800 x 350	185

TECHNICAL DATA SHEET

LPI® Bluetooth Range of Surge Filters

Single Phase Surge Filters

Surge Filter Type:	Nominal Operating Voltage U_n : @ 50/60 Hz	Surge Rating (I_{max}): @ 8/20 μ s Per SST150B module primary/secondary	Secondary Nominal Discharge Current (I_n): @ 8/20 μ s	Max. Continuous Operating Voltage (U_c):	Response Time:	Power Distribution Systems:
SF1-230	110-120Vac	50 kA	20 kA	230 Vrms	<5 ns	WYE, L-N mode
SF1-385	220-240 Vac	50 kA	20 kA	385 Vrms	<5 ns	TN, TT & for L-N mode
SF1-480	220-277 Vac	50 kA	20 kA	480 Vrms	<5 ns	TT & TN

Split Phase Surge Filters (32A – 125A)

Surge Filter Type:	Nominal Operating Voltage U_n : @ 50/60 Hz	Surge Rating (I_{max}): @ 8/20 μ s Per SST150B module primary/secondary	Secondary Nominal Discharge Current (I_n): @ 8/20 μ s	Max. Continuous Operating Voltage (U_c):	Response Time:	Power Distribution Systems:
SF2-230	110-120Vac	50 kA	20 kA	230 Vrms	<5 ns	Split Phase L-N mode

3 Phase Surge Filters (32 A – 125 A)

Surge Filter Type:	Nominal Operating Voltage U_n : @ 50/60 Hz	Surge Rating (I_{max}): @ 8/20 μ s Per SST150B module primary/secondary	Secondary Nominal Discharge Current (I_n): @ 8/20 μ s	Max. Continuous Operating Voltage (U_c):	Response Time:	Power Distribution Systems:
SF3-230	110-120Vac	50 kA	20 kA	230 Vrms	< 5 ns	WYE for L-N mode
SF3-385	220-240 Vac	50 kA	20 kA	385 Vrms	<5 ns	TN, TT & for L-N mode
SF3-480	220-277 Vac	50 kA	20 kA	480 Vrms	<5 ns	TT & TN

3 Phase Surge Filters (200 A – 630 A)

Surge Filter Type:	Nominal Operating Voltage U_n : @ 50/60 Hz	Primary Surge Rating (I_{max}): @ 8/20 μ s	Secondary Surge Rating (I_{max}): @ 8/20 μ s	Secondary Nominal Discharge Current (I_n): @ 8/20 μ s	Max. Continuous Operating Voltage (U_c):	Response Time:	Power Distribution Systems:
SF3-230	110—230Vac	135 kA	50 kA	20 kA	230 Vrms	<5 ns	WYE for L-N mode
SF3-385	220-240 Vac	135 kA	50 kA	20 kA	385 Vrms	<5 ns	TN, TT & for L-N mode
SF3-480	220-277 Vac	135 kA	50 kA	20 kA	480 Vrms	<5 ns	TT & TN

TECHNICAL DATA SHEET

3 Phase Surge Filters (800 A – 2000 A)

Surge Filter Type:	Nominal Operating Voltage U_n : @ 50/60 Hz	Primary Surge Rating (I_{imp}): @ 10/350 μ s	Secondary Surge Rating (I_{max}): @ 8/20 μ s	Secondary Nominal Discharge Current (I_n): @ 8/20 μ s	Max. Continuous Operating Voltage (U_c):	Response Time:	Power Distribution Systems:
SF3-230	110—230Vac	100 kA	50 kA	20 kA	230 Vrms	<5 ns	WYE for L-N mode
SF3-385	220-240 Vac	100 kA	50 kA	20 kA	385 Vrms	<5 ns	TN, TT & for L-N mode
SF3-480	220-277 Vac	100 kA	50 kA	20 kA	480 Vrms	<5 ns	TT & TN

Surge Filter Part Number Key

Product Type T	Phases UU	Load Current (A) VVVV	MCOV (V) WWW	Primary Protection (8/20 μ s unless specified) XXX	Secondary Protection (8/20 μ s) YYY	Alarm Module Z
SF	1	32	230	100 kA	50 kA	AIMCB
	3	40	385	150 kA	100 kA	
		63	480			
		125				
		200		≥ 200 A: 135 kA		
		315				
		400		≥ 800 A: 100 kA (10/350 μ s)		
		630				
		800				
		1000				
		1250				
		1500				
		1750				
		2000				

Surge Filter Ordering Code:

Product Order Code: T-UU-VVVV-WWW-XXX-YYY-Z

Refer to above part number key.

1. First select product type which for surge filter = SF.
2. Select number of phases.
3. Select load current.
4. Select operating voltage.
5. Select primary protection. Note: for surge filters 200 A and above primary protection is 135 kA.
6. Select secondary protection.
7. Include alarm module.

Example product code for single phase filter = **SF132-385-100+50-AIMCB**

Example product code for three phase filter = **SF3125-385-150+50-AIMCB**

Example product code for three phase filter 200 A and above = **SF3630-480-135-50-AIMCB**

Example product code for three phase filter 800 A and above = **SF3800-480-100-50-AIMCB**

TECHNICAL DATA SHEET

Notes:

- All filters are fitted with 100 kA 10/350 μ s or 200 kA 8/20 μ s neutral earth protection.
- 630 – 2000 A current ratings filters have had a redesign of the busbar network that provides the integral inductor (replacing a separate steel core inductor) that forms part of the L-C filter network within the product.
- Busbars are no longer tinned for filters rated at 1500 A and above
- All filters are supplied with cable ties securing SST150B modules for transport purposes. Remove all cable ties when installing.

Installation & Maintenance for Surge Filters

All installation work *must* be carried out by licensed electrical personnel.

The power *must* be disconnected. Ensure no dangerous neutral to earth voltages exist prior to commencing installation work.

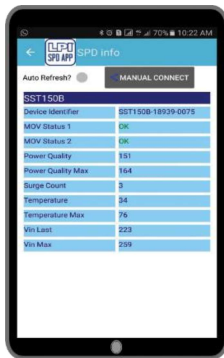

Operational



Replace as protection is reduced

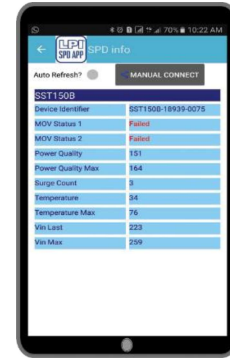

Replace as no protection is left

1. The surge filter should be installed as close as practical to the power distribution panel. Filters rated at 315 A and above are fitted with two mounting rails to assist with mounting the unit to the wall.
2. The input and output power cables that connect to the surge filter must have a current rating at least equal to that of the unit being installed.
3. All cables are routed through the bottom of the cabinet. Suitable cable glands should be fitted to the gland plates. All connection points are clearly labelled on the backplane.
4. Connect the input and output power lines as illustrated in figure 4 and figure 5. Input cables are considered “dirty” and must be physically separate by at least 300 mm from the “clean” output cables. This will prevent any over voltage carried by the incoming cables from being induced onto the outgoing or “clean” cables.
5. The earthing impedance of the electrical system should be less than 10 Ω , with 5 Ω recommended.
6. Connect the earth terminal on the surge filter unit to the nearest electrical main earth using the shortest possible route. Earthing cable should be a minimum of 16 mm² with 25 mm² recommended.
7. All connections must be rechecked to confirm that they are securely connected.

TECHNICAL DATA SHEET

- Connect power to the surge filter and confirm that power is being delivered to the load and that all status indicators are green. The surge filter is in series with the load and turning off the filter's internal circuit protection will disconnect power to the load.

- 32 A, 40 A and 63 A with MCCB built in
- 125 A and above no MCCB

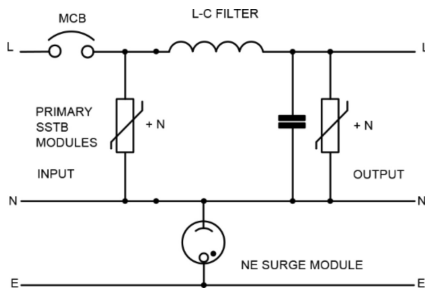

Schematic of 1 Ø surge filter

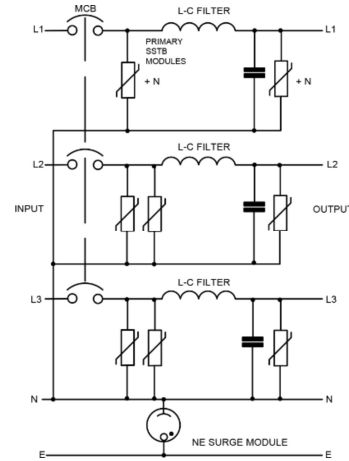

Schematic of 3 Ø surge filter

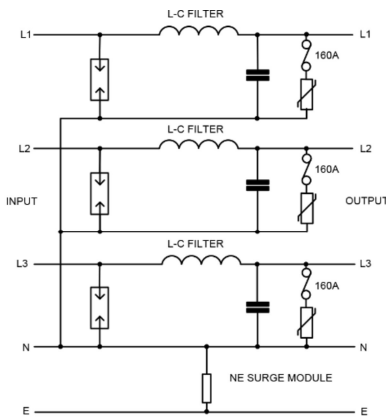

Figure 4

Schematic of 3 Ø surge filter (400 A and below, no 160 A fuse on filters below 125A)

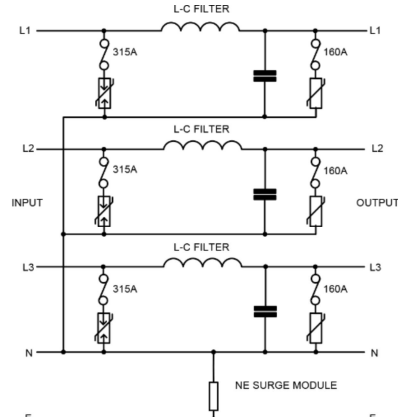

Figure 5

Schematic of 3 Ø surge filter (above 400 A)

Maintenance

1. Use LPI Bluetooth connectivity to check the status of all modules.
2. Do not perform maintenance work until power to the surge filter has been disconnected.
3. All surge protection devices will degrade and must be replaced at the end of their life cycle. The frequency of replacement is subject to the magnitude and number of incident surges applied to the device – therefore status indication is very important.

TECHNICAL DATA SHEET

All filters are supplied with cable ties securing SST150B modules for transport purposes only. Remove all cable ties when installing.

User Guide for LPI® Bluetooth SPD Demo Kit

1. Remove unit from case and ensure that SST150B and NE15B modules are seated correctly in the demonstration panel.
2. The demonstration panel comes complete with USB power cable to boost voltage, using a different cable will result in erratic operation.
3. The SPD modules in this demonstration kit are specifically designed for use with this demonstration panel only. The SPDs should not be sold as a finished product nor should finished product be swapped out for us with demonstration unit.
4. To reset information within the SST150B and NE15B, disconnect power and wait several seconds, while holding down the reset button reconnect power allowing 5 seconds and then release reset button. All values in both SST150B and NE15B will be zeroed out. **(this is not a feature of the production units)**
5. While the update of information is instant via the SPD APP, a time delay will be witnessed between failure activation and alarm trip on the demonstration panel. This is normal, the AIM module poles the connected units every 30secs to confirm failure to ensure nuisance tripping is eliminated.
6. The system uses a common alarm output so when a fault has been activated, subsequent faults will be indicated by red flashing LEDS on effected units.
7. Ensure SPD app is downloaded and is working on desired device.
8. Ensure Bluetooth is enabled on your device.
9. Ensure that both SST150B and NE15B have been reset.
10. On occasions the SPD app may become non-responsive or time out, to overcome this force quite the application to shut it down and then re-load.

The purpose of this demonstration is to show the Bluetooth capability of the SPD modules via interaction with the demonstration panel and the SPD app.

Contact LPI or local distributor for demonstration instructions for the SST150B Demo Kit.

TECHNICAL DATA SHEET

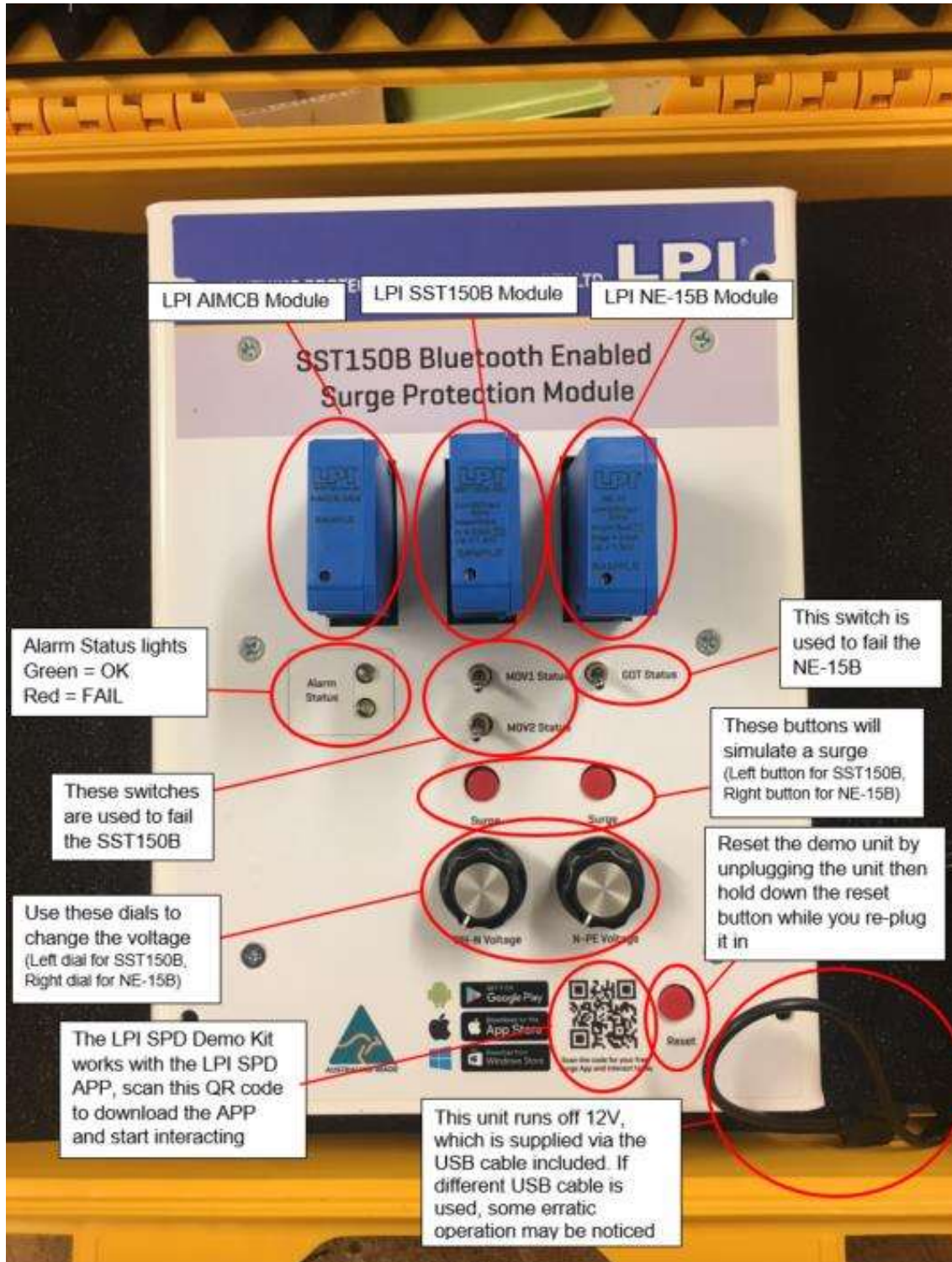

LPI AIMCB Module

LPI SST150B Module

LPI NE-15B Module

SST150B Bluetooth Enabled Surge Protection Module

Alarm Status lights
Green = OK
Red = FAIL

This switch is used to fail the NE-15B

These switches are used to fail the SST150B

These buttons will simulate a surge (Left button for SST150B, Right button for NE-15B)

Use these dials to change the voltage (Left dial for SST150B, Right dial for NE-15B)

Reset the demo unit by unplugging the unit then hold down the reset button while you re-plug it in

The LPI SPD Demo Kit works with the LPI SPD APP, scan this QR code to download the APP and start interacting

This unit runs off 12V, which is supplied via the USB cable included. If different USB cable is used, some erratic operation may be noticed

Head Office 49 Patriarch Drive, Huntingfield Tasmania, Australia 7055
Postal PO Box 379 Kingston, Tasmania, Australia 7051
Web www.lpi.com.au

Phone + 61 3 6281 2475
Facsimile + 61 3 6229 1900
Email info@lpi.com.au